



- PoE option
- IEEE 1588 PTP
- Trigger over Ethernet
- Auto iris
- Angled head option
- Board level option
- 286 fps

Simplify your setup of multi-camera applications

Modular machine vision camera with GigE Vision interface

Manta G-040 with Sony IMX287 runs 286.0 frames per second at 0.4 MP resolution.

Manta is Allied Vision's most versatile GigE Vision camera series. It provides the largest choice of image sensors and its advanced feature set simplifies the setup of multi-camera applications. With its modular hardware concept, Manta offers nearly endless configuration possibilities to adapt the camera to your application.

Easy software integration with Allied Vision's [Vimba Suite](#) and compatibility to the most popular [third party image-processing libraries](#).

See the [Modular Concept](#) for lens mount, housing variants, optical filters, case design, and other modular options. See the [Customization and OEM Solutions](#) webpage for additional options.

Specifications

Interface	IEEE 802.3 1000BASE-T, IEEE 802.3af (PoE) optional
Resolution	728 (H) × 544 (V)
Sensor	Sony IMX287
Sensor type	CMOS
Shutter mode	GS (Global shutter)
Sensor size	Type 1/2.9
Pixel size	6.9 μm × 6.9 μm
Lens mounts (available)	C-Mount, CS-Mount
Max. frame rate at full resolution	286 fps
ADC	12 Bit
Image buffer (RAM)	128 MByte

Imaging performance

Imaging performance data is based on the evaluation methods in the EMVA 1288 Release 3.1 standard for characterization of image sensors and cameras. Measurements are typical values for monochrome models measured at full resolution without optical filter. Contact Sales or AE for more information.

Quantum efficiency at 529 nm	64 %
Temporal dark noise	3.1 e ⁻
Saturation capacity	20800 e ⁻
Dynamic range	74.4 dB
Absolute sensitivity threshold	4.0 e ⁻

Output

Bit depth	8-bit or 12-bit
Monochrome pixel formats	Mono8, Mono12Packed, Mono12
YUV color pixel formats	YUV411Packed, YUV422Packed, YUV444Packed
RGB color pixel formats	RGB8Packed, BGR8Packed
Raw color pixel formats (Bayer)	BayerRG8, BayerRG12, BayerRG12Packed

General purpose inputs/outputs (GPIOs)

Opto-isolated I/Os 2 inputs, 2 outputs

RS232 1

Operating conditions/dimensions

Operating temperature +5 °C to +45 °C ambient (without condensation)

Power requirements (DC) 8 to 30 VDC AUX or IEEE 802.3af PoE

Power consumption External power: 2.77 W at 12 VDC | Power over Ethernet: 3.23 W

Mass 190 g; 200 g (PoE models)

Body dimensions (L × W × H in mm) 86.3 × 44 × 29 (including connectors)

Quantum efficiency

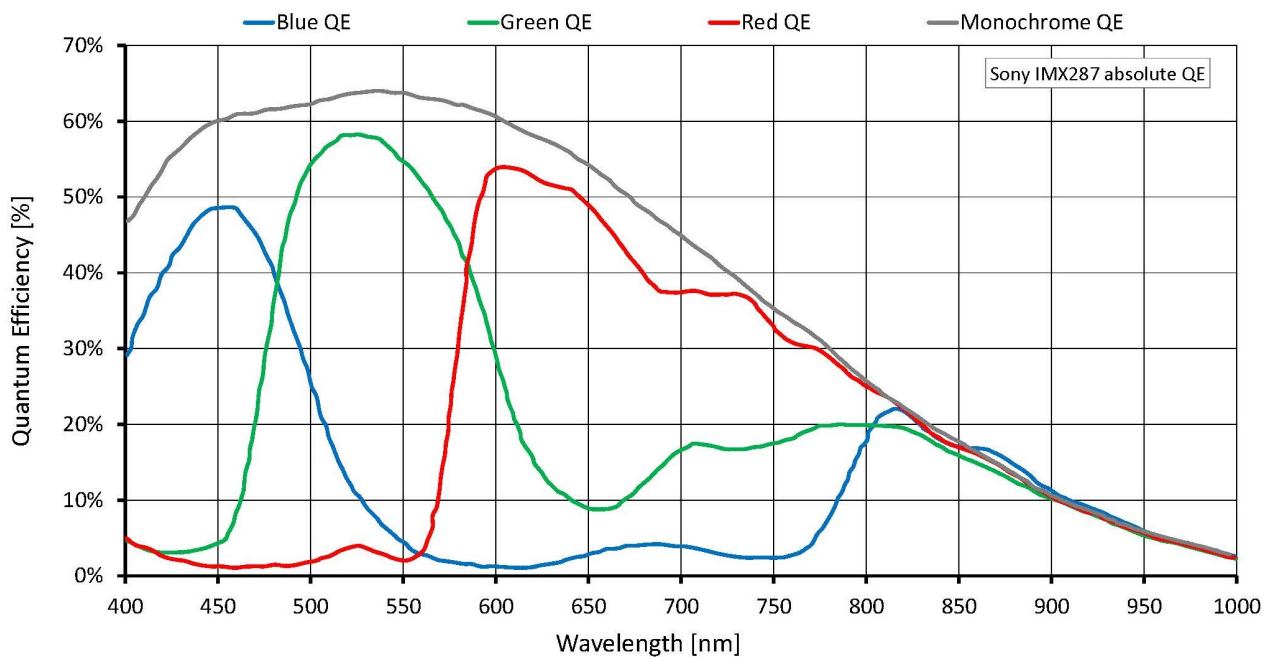

Features

Image control: Auto

- Auto exposure
- Auto gain
- Auto white balance (color models)

Image control: Other

- Binning
- Black level
- Color transformation (incl. hue, saturation; color models)
- Decimation
- Gamma
- LUT (look-up table)
- Reverse X
- ROI (region of interest)

Camera control

- Acquisition frame rate
- Action commands, incl. ToE (trigger over Ethernet)
- Auto iris
- Bandwidth control
- Event channel
- Firmware update in the field
- I/O and trigger control
- Image chunk data
- PTP (IEEE 1588 Precision Time Protocol)
- Stream hold
- Temperature monitoring
- User sets

Technical drawing

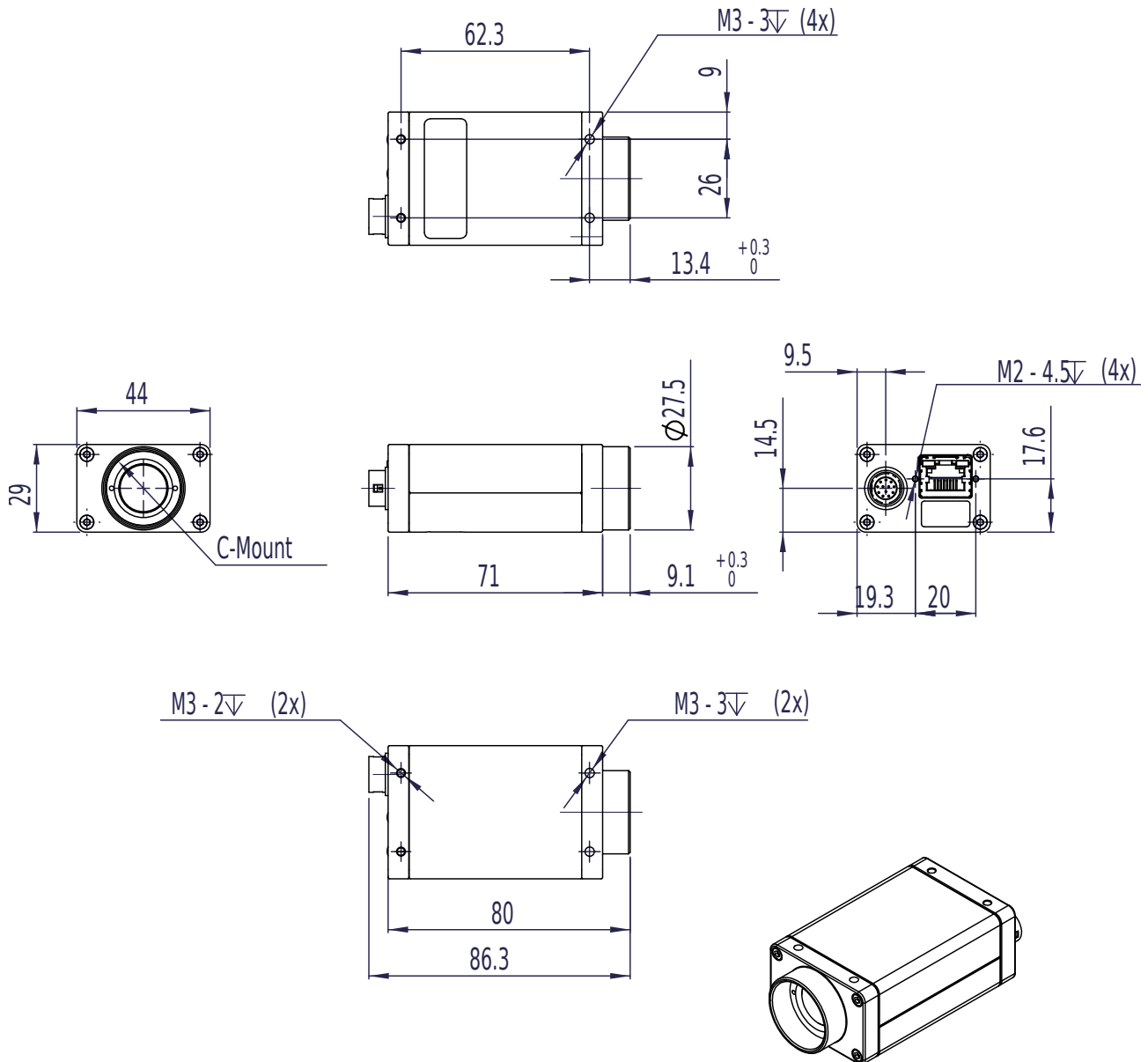

Applications

The Manta G-040 is the perfect model for industrial applications that require accurate imaging of fast-moving subjects. Equipped with a Pregius global shutter function, the camera provides high-quality image capture that is not affected by focal plane distortion or flash bands. The Sony IMX287's 6.9 $\mu\text{m} \times 6.9 \mu\text{m}$ pixel size achieves sensitivity four times that of the IMX273. This means that the same sensor output can be obtained with a shorter shutter time, making it possible to increase inspection

speeds in factories. In addition, high sensitivity is achieved even in the near-infrared wavelength band that generally has low quantum efficiency, thereby realizing superior performance.

Manta G-040 is ideal for a wide range of applications including:

- Machine Vision
- Industrial inspection
- Security and surveillance
- Intelligent traffic solutions (ITS) including traffic monitoring, speed enforcement, and toll collection
- Low light and/or high sensitivity conditions
- Outdoor applications with dynamic lighting situations